



# RECOIL PAD TEMPLATE GUIDE

## WHY USE TEMPLATES?

Many manufacturers modify their stock dimensions yearly, making it difficult for us to keep one specific model available for one specific manufacturer. In response, we have provided these templates to help you match your gun stock butt.

## OTHER OPTIONS

If you have a stock that does not match one of our templates, you can utilize our Slip-On pad which delivers the same felt recoil reduction as our Precision-Fit pad. (Removal of existing pad is recommended, but not required.) You may also utilize our Grind-to-Fit recoil pad, but this may require a visit to your local gunsmith.

## TEMPLATE INSTRUCTIONS

**\*NOTE: When printing, make sure that the "PRINT ACTUAL SIZE" or "CONSTRAIN PROPORTIONS" box is checked or that the "FIT TO PAGE" box is unchecked (found in Print Settings). These templates will not work if they are not printed 100% to size.** You can verify the size by measuring a printed template and comparing to the measurements written on the template.

- I. Remove the existing recoil pad or plate from your stock butt by unscrewing. If your recoil pad is glued on, it may require gunsmithing.
- II. Place the gun stock on top of each template until you have found a match. Cut template out to determine screw hole location. If the screw holes do not line up, you can slot or elongate the screw holes on the bottom of our plate an additional 3/16" or more towards the heel or the toe and 1/16" towards the center of the pad (use a Dremel® tool with sanding attachment) to match the holes in your stock. This is regardless of wood or synthetic stocks. Please note: This only refers to the template recoil pads that are not already elongated or slotted.
- III. Once a match is found, the product number will be on that specific template so you will know which one to order.

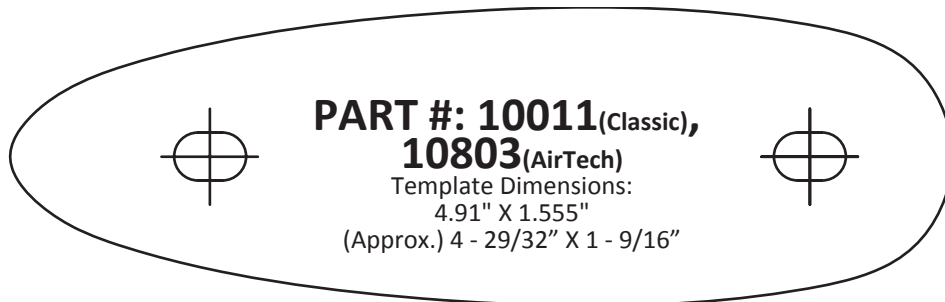
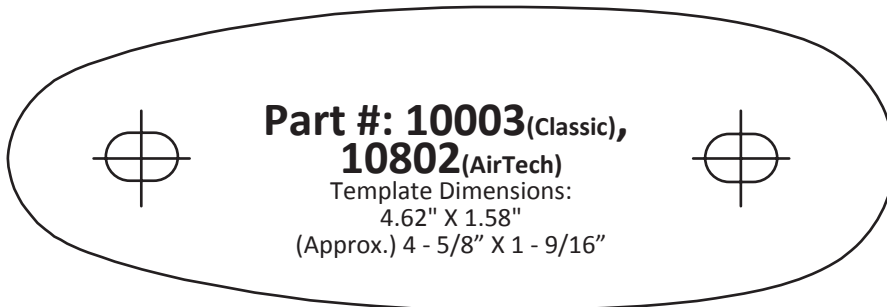
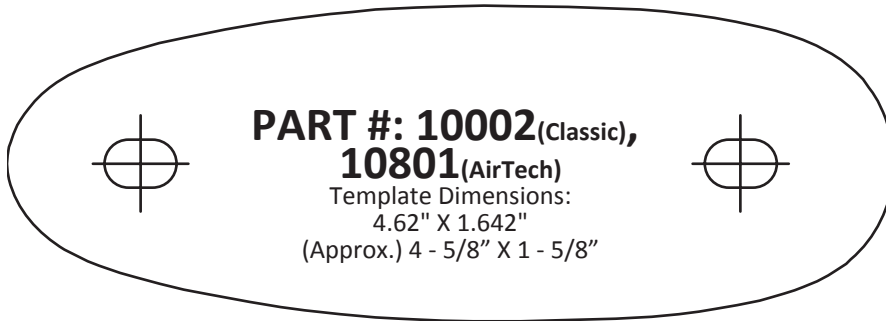
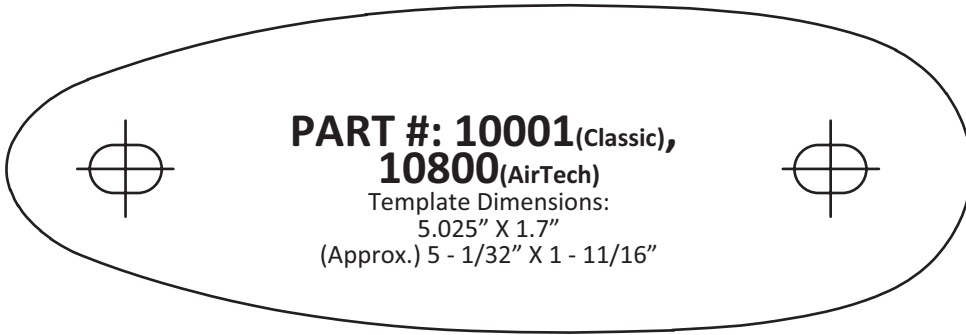

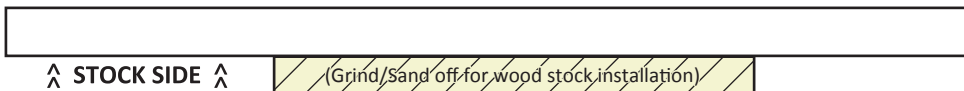
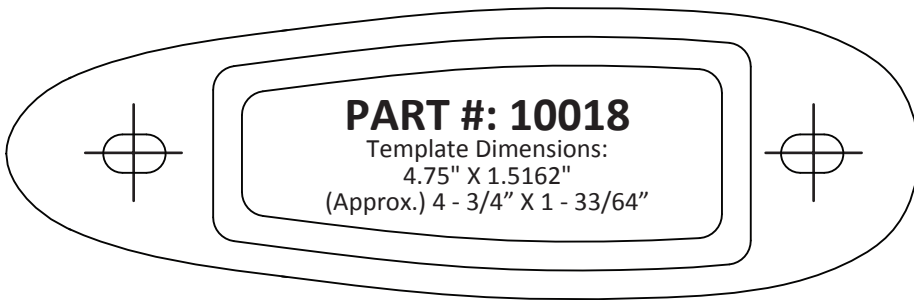
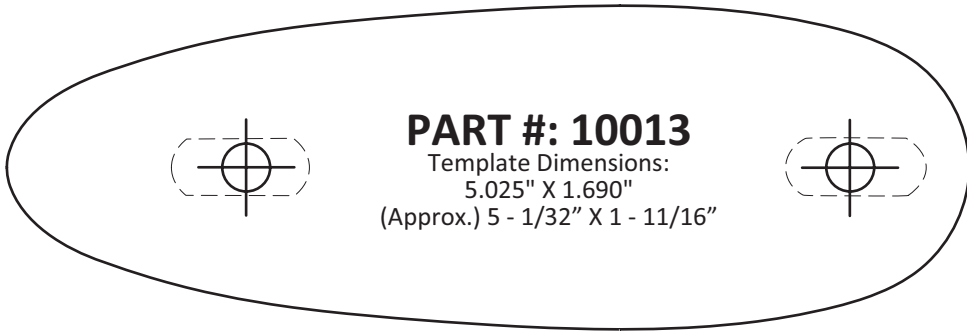
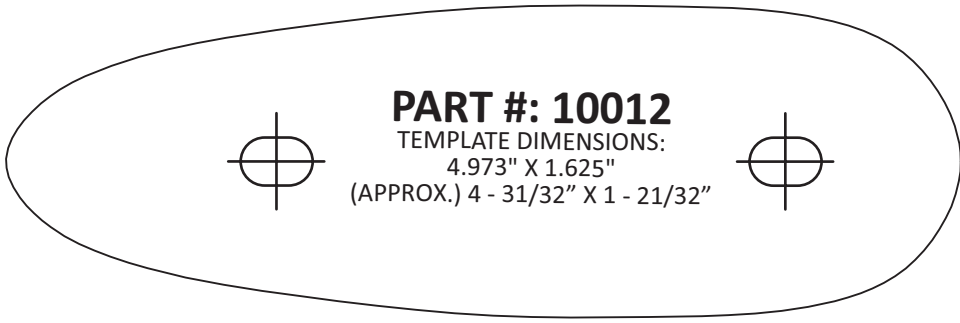

TACTICAL

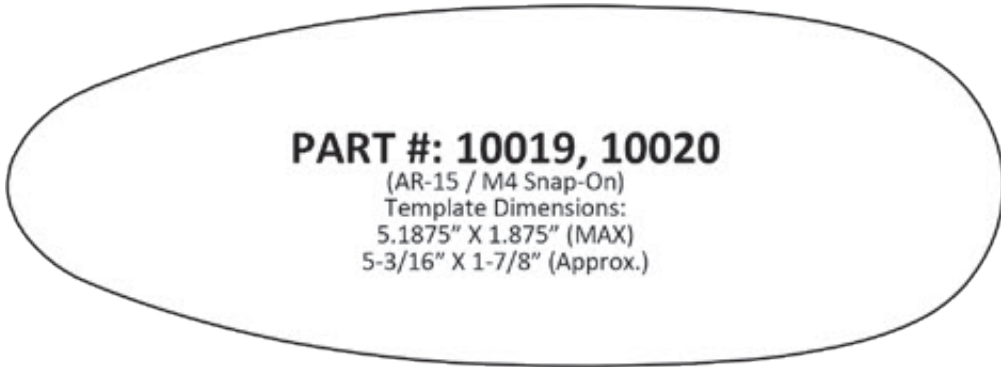

AR-15 Universal 6-Position Tactical (1/4" step-down)  
 Tapco T6, Colt LE6920, LE6940  
**SNAP-ON ONLY - No screw holes**

TACTICAL

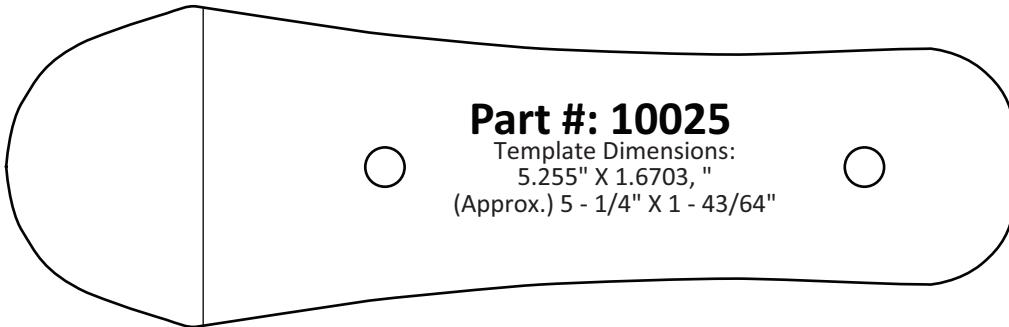

Magpul STR, ACS, ACS-L, UBR, Mil Spec, CTR, MOE (MAG 310 & MAG 400)

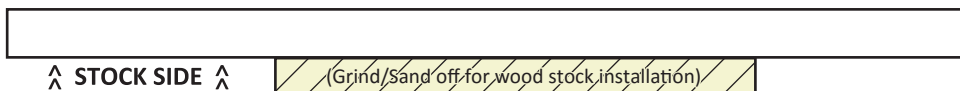
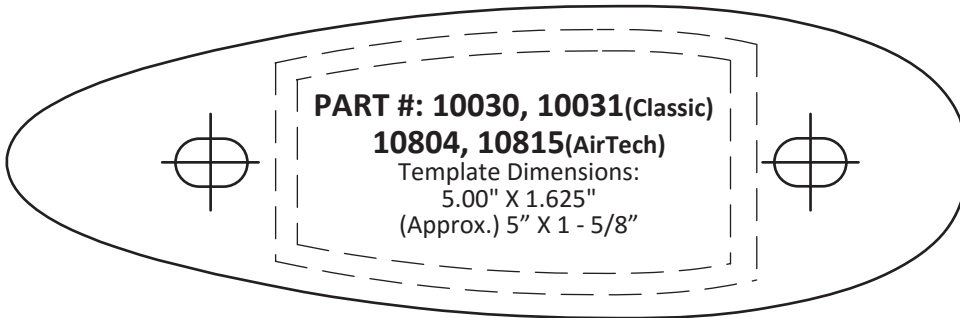

10031/10815: for wood stocks only  
 10031/10804: for synthetic stocks only

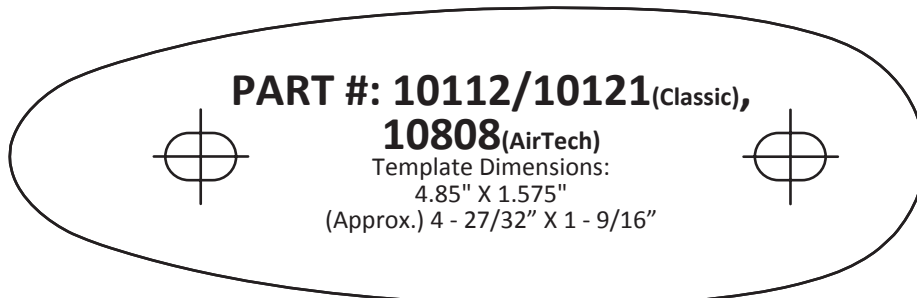
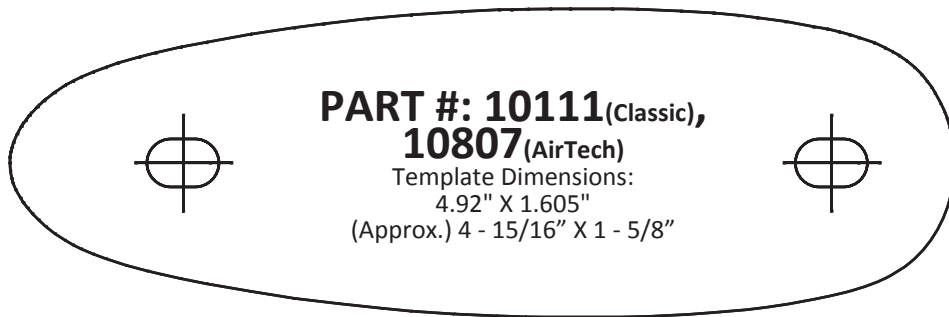
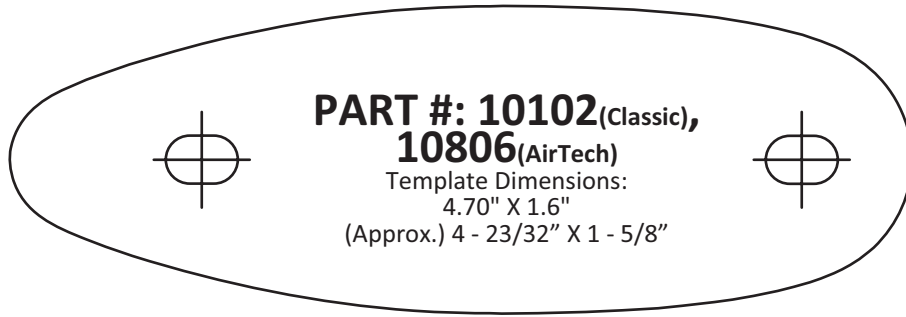

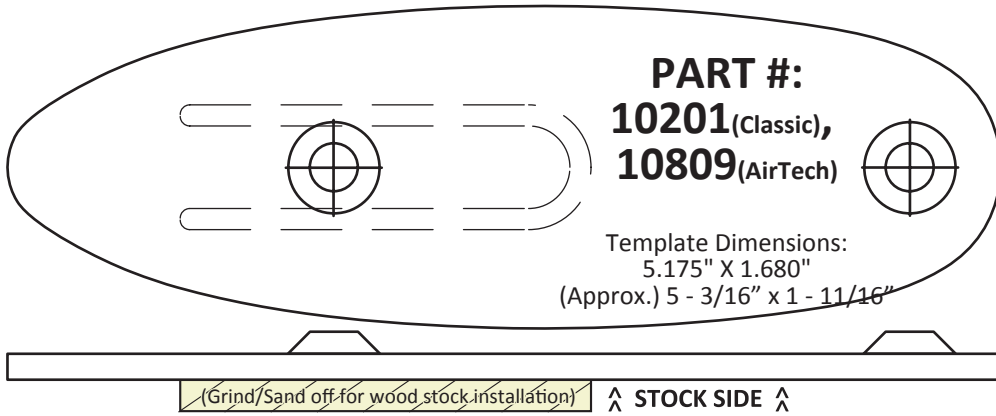

INCLUDES ADAPTER PIECE.

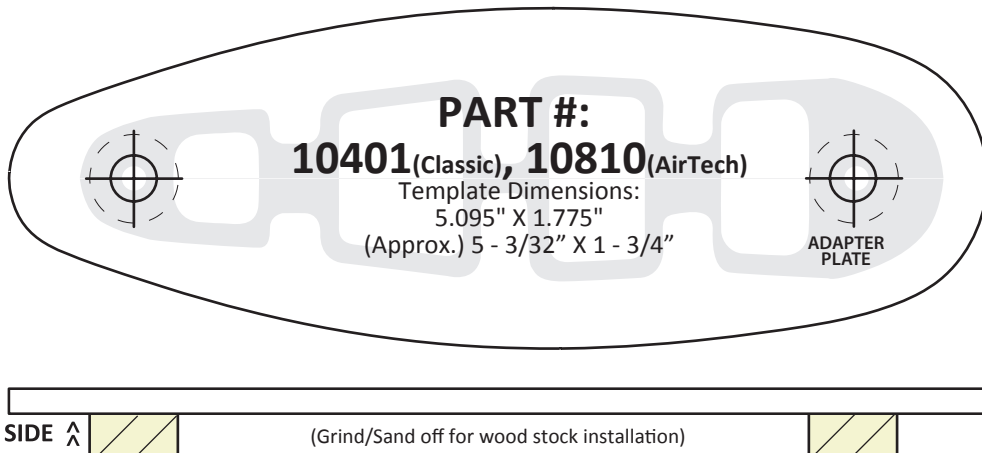
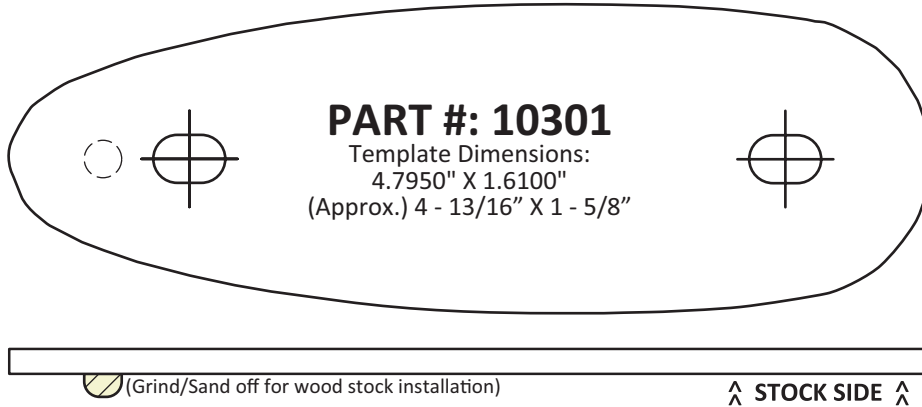

INCLUDES ADAPTER PIECE.

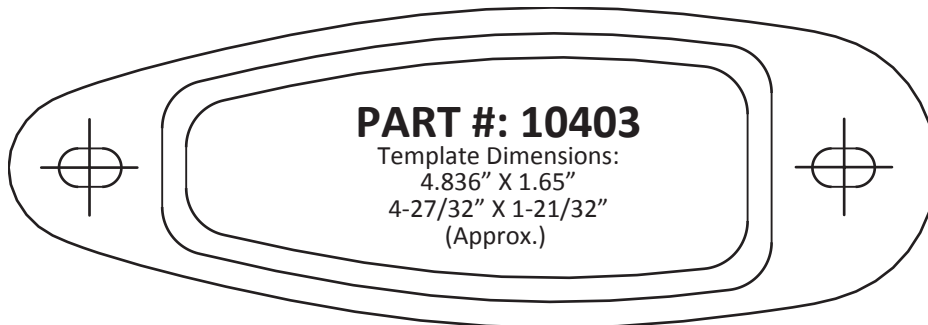

Benelli M1 Tactical, SBE II Std. Grip  
(Bolt-On)

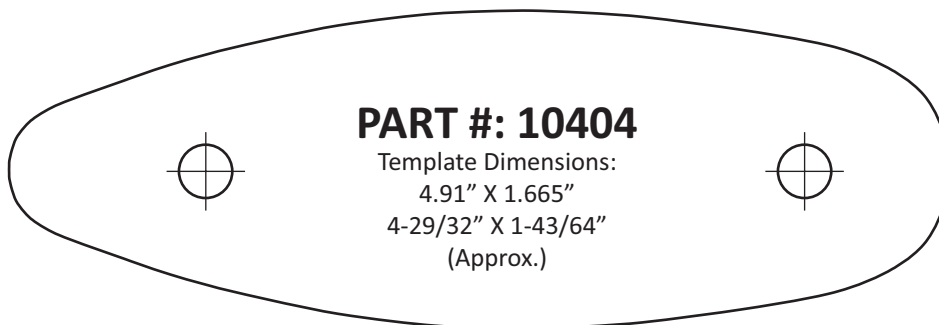

Benelli M2 Tactical, Supernova Tactical, SBE II Std. Grip  
(Snap On)

INCLUDES ADAPTER PIECE.

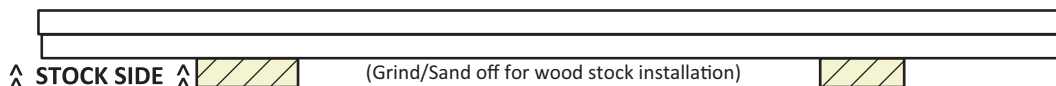
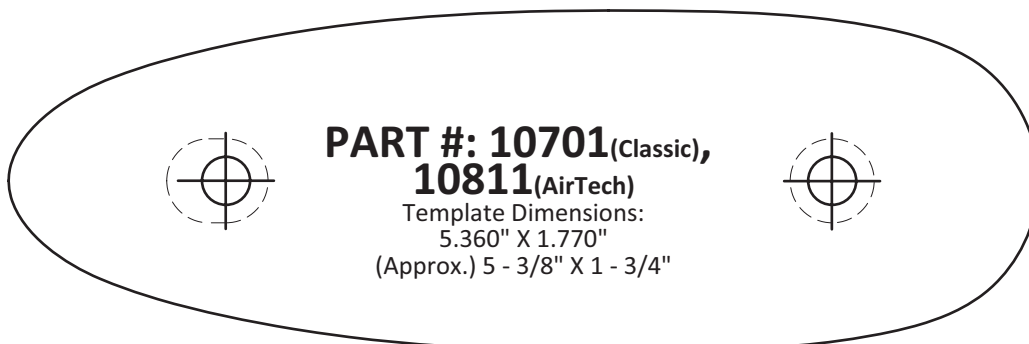
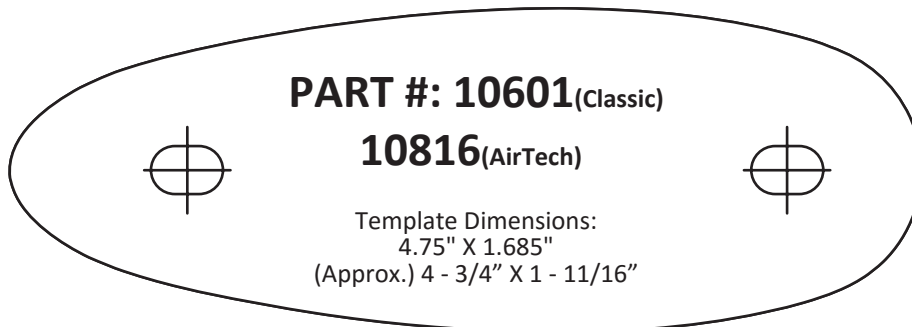

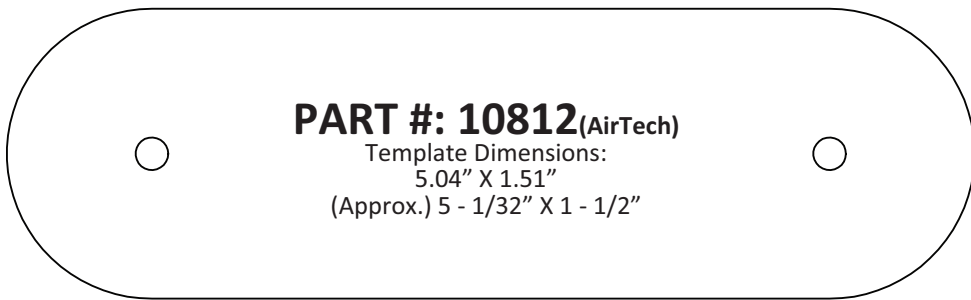
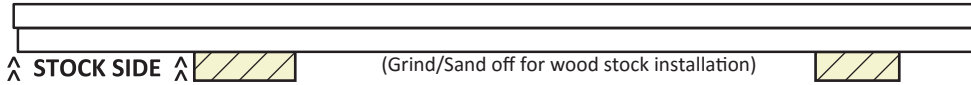
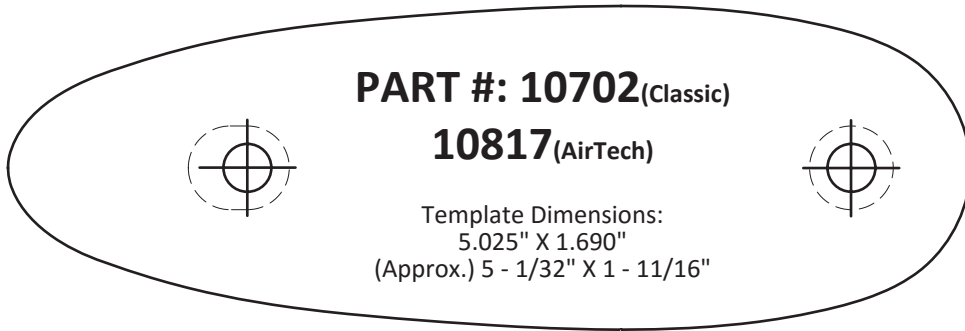

Choate

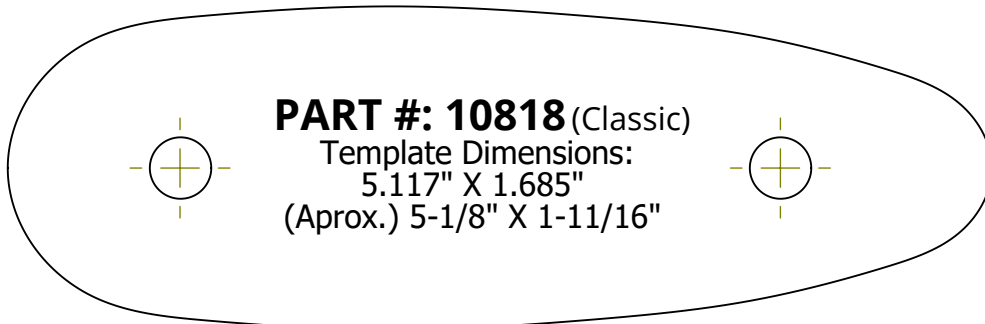
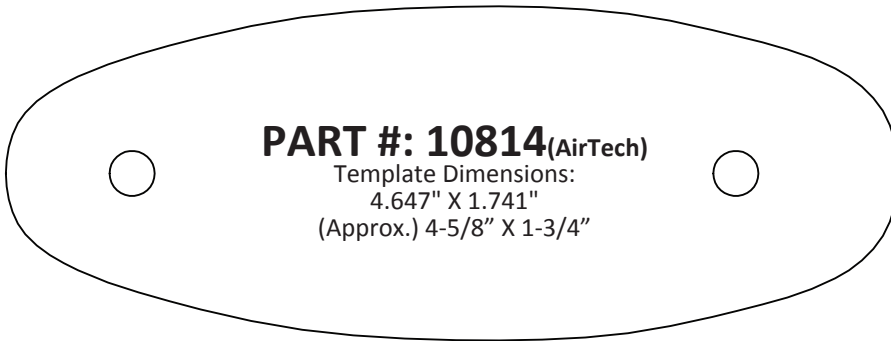



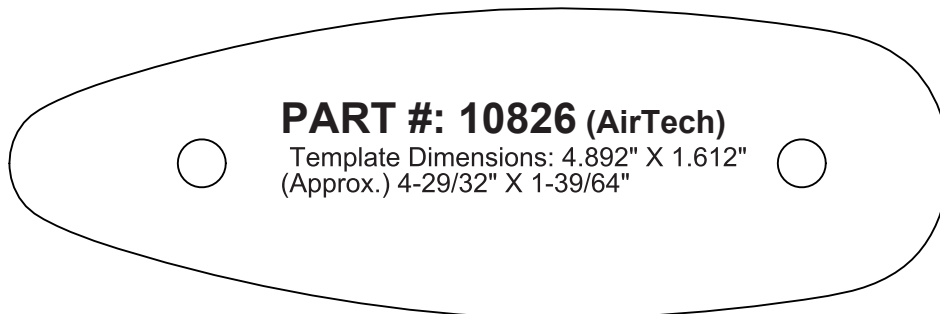
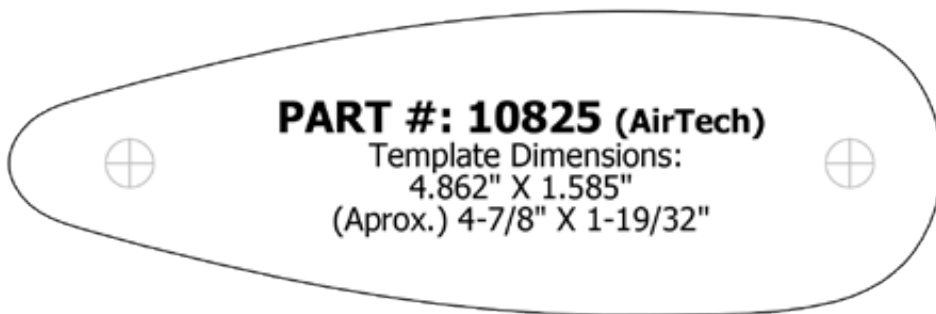
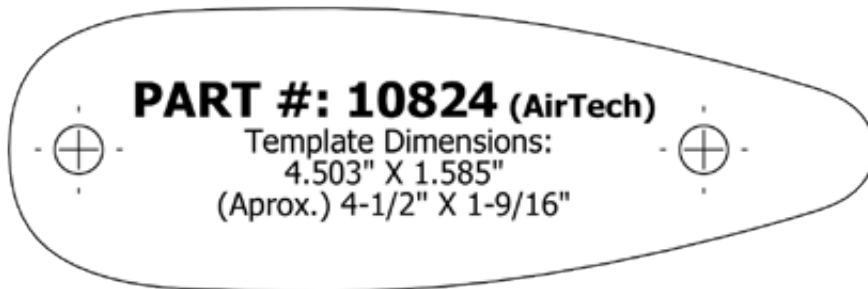
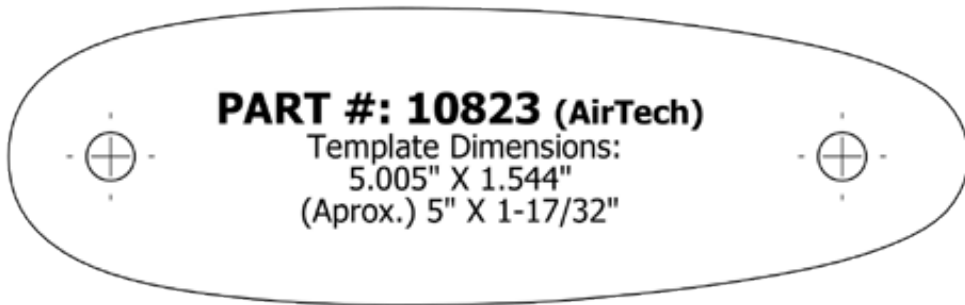

The following two templates on this page were designed to fit a specific make of synthetic stock. To accomplish as accurate a fit as possible, many of the synthetic recoil pad plates have profiles that snap inside the cavities of the stock. While most plates can be modified to fit a wood stock by grinding off any protruding plastic on the plate, the following two plates CANNOT be altered.

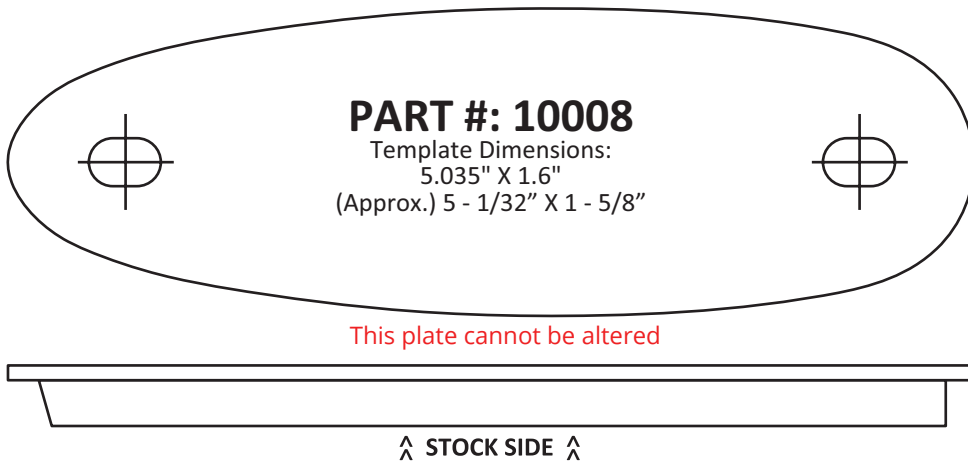

Browning Gold 12/20; Stoeneger M2000 (non-pistol grip & P-350 pump (syn.), Silver 12 GA. (Syn.)

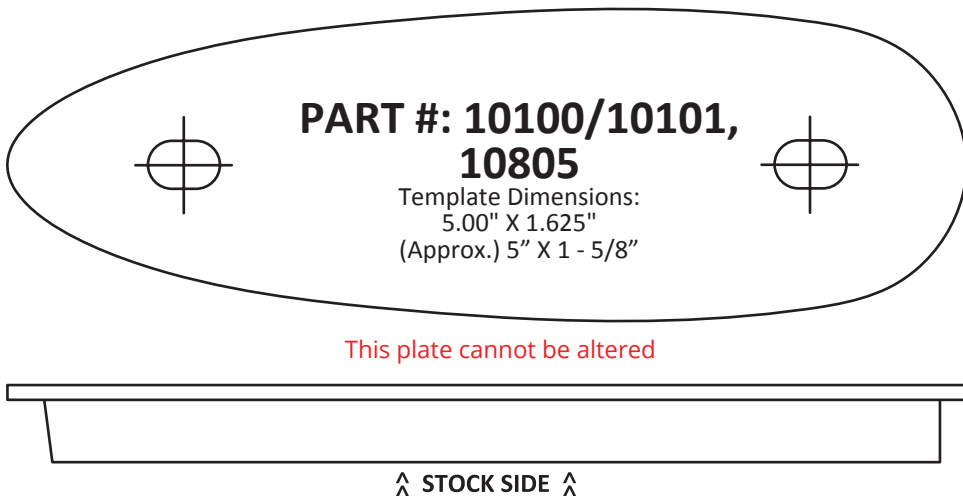

Remington 700 ADL/BDL, ML, 710, 770, 7600, 870, (12, 16), 1100 (12, 16), 11-87 (syn.), SP-10; Marlin XS7 (syn.)

# LIMBSAVER GRIND-TO-FIT RECOIL PAD TEMPLATES

The following Grind-to-Fit Recoil Pads are shown with two profile lines. The outer line is the actual size of the pad. The inner line is the "Max" Grind line. In order for our technology to function properly, the interior air chamber must remain intact with enough wall thickness to contain the pressure during the firing of the weapon. By not grinding past this line, you ensure your pad will be in perfect working order. To determine which Grind-to-Fit Recoil Pad is right for you, remove your existing pad, and place your flat stock on the templates. Choose the pad that shows the full outer line of the template, and none of the interior line. For further instructions, see inside of our packaging, or go to [www.LimbSaver.com](http://www.LimbSaver.com).

## SMALL GRIND-TO-FIT

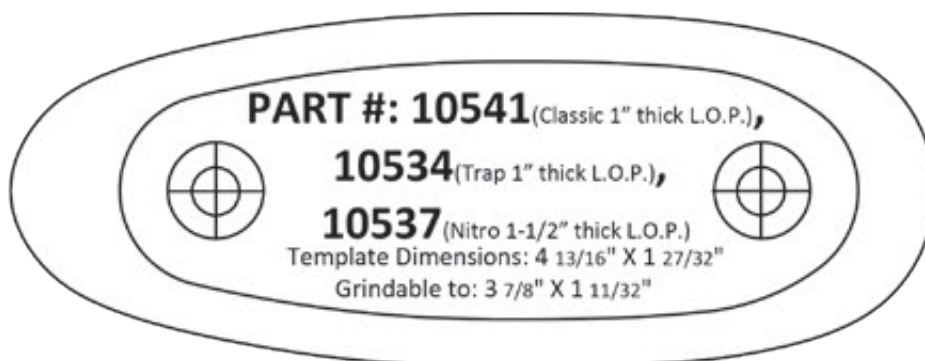

10541 is a Classic LimbSaver pad with 1" LOP  
10534 is a Trap LimbSaver pad with 1" LOP  
10537 is a Nitro LimbSaver pad with 1-1/2" LOP

## MEDIUM GRIND-TO-FIT

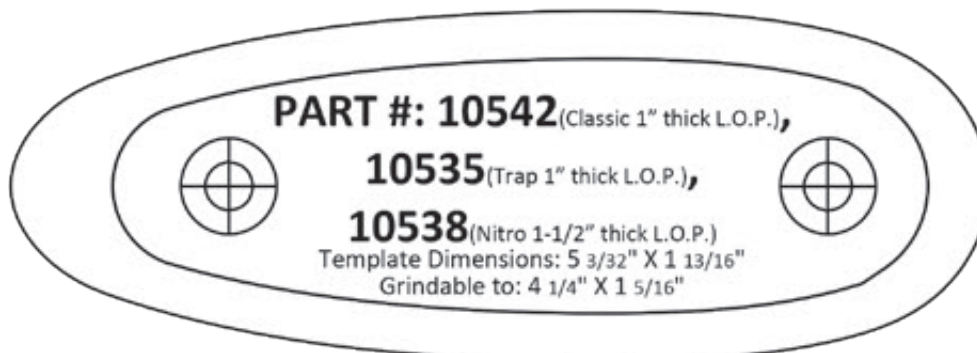

10542 is a Classic LimbSaver pad with 1" LOP  
10535 is a Trap LimbSaver pad with 1" LOP  
10538 is a Nitro LimbSaver pad with 1-1/2" LOP

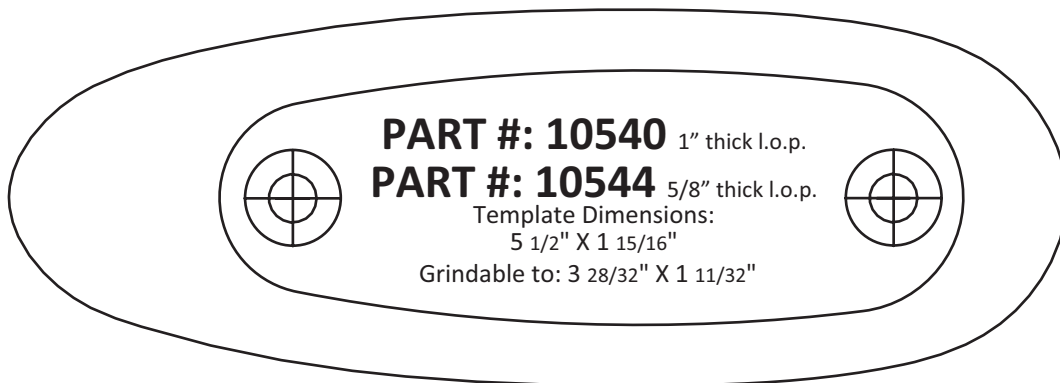

10540 is a Speed Mount LimbSaver pad with 1" LOP  
 10544 is a Classic LimbSaver pad with 5/8" LOP

### LARGE GRIND-TO-FIT

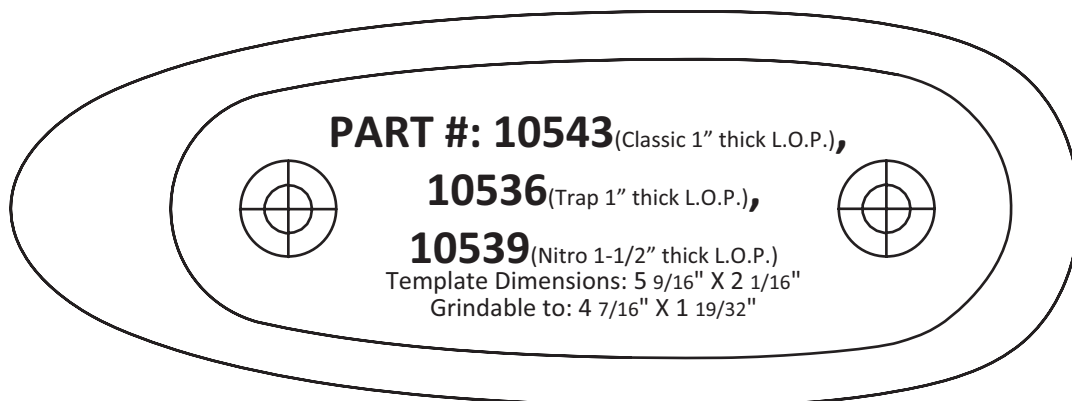

10543 is a Classic LimbSaver pad with 1" LOP  
 10536 is a Trap LimbSaver pad with 1" LOP  
 10539 is a Nitro LimbSaver pad with 1-1/2" LOP

# RECOIL PAD FITTING GUIDE

## MEASUREMENTS FOR GRIND-TO-FIT RECOIL PADS

Please also use our templates to ensure proper fit.

\*All Grind-to-Fit® pads are designed for flat butt stocks

SIZE	MEASUREMENTS	MODEL
<b>CLASSIC GRIND-TO-FIT®:</b> (Flat butt stocks only. 1" thick)		
S	4 13/16" X 1 27/32" Grindable To: 3 7/8" X 1 11/32"	10541
M	5 3/32" X 1 13/16" Grindable To: 4 1/4" X 1 5/16"	10542
L	5 9/16" X 2 1/16" Grindable To: 4 7/16" X 1 19/32"	10543
<b>LOW PROFILE GRIND-TO-FIT®:</b> (Flat butt stocks only. 5/8" thick)		
Med+	5 1/2" X 1 31/32" Grindable To: 3 29/32" X 1 11/32" (5/8" Thick)	10544
<b>NITRO GRIND-TO-FIT®:</b> (Flat butt stocks only. 1 1/2" thick)		
S	4 13/16" X 1 27/32" Grindable To: 3 7/8" X 1 11/32"	10537
M	5 3/32" X 1 13/16" Grindable To: 4 1/4" X 1 5/16"	10538
L	5 9/16" X 2 1/16" Grindable To: 4 7/16" X 1 19/32"	10539
<b>TRAP / SKEET GRIND-TO-FIT®:</b> (Flat butt stocks only. 1" thick) Curved/Contoured Design		
S	4 13/16" X 1 27/32" Grindable To: 3 7/8" X 1 11/32"	10534
M	5 3/32" X 1 13/16" Grindable To: 4 1/4" X 1 5/16"	10535
L	5 9/16" X 2 1/16" Grindable To: 4 7/16" X 1 19/32"	10536
<b>SPEED MOUNT GRIND-TO-FIT®:</b> (Flat butt stocks only. 1" thick) Sloped design.		
Med+	5 1/2" X 1 31/32" Grindable To: 3 29/32" X 1 11/32"	10540

## MEASUREMENTS FOR SLIP-ON RECOIL PADS

SIZE	MEASUREMENTS	MODEL
<b>CLASSIC SLIP-ON RECOIL PAD:</b> (Universal. Approx. 1" thick unless otherwise noted.)		
S	4 1/2" X 1 1/2" Up to 4 13/16" X 1 5/8"	10546
S/M	4 5/8" X 1 9/16" Up to 5 1/8" X 1 3/4" (1/2" thick)	10545
M	4 13/16" X 1 5/8" Up to 5 1/8" X 1 3/4"	10547
L	5 1/8" X 1 3/4" Up to 5 3/8" X 1 7/8"	10548
<b>AIR-TECH® SLIP-ON RECOIL PAD:</b> (Universal. Approx. 1" thick unless otherwise noted.)		
S	4 1/2" X 1 1/2" Up to 4 13/16" X 1 5/8"	10550
S/M	4 5/8" X 1 9/16" Up to 5 1/8" X 1 3/4" (1/2" thick)	10549
M	4 13/16" X 1 5/8" Up to 5 1/8" X 1 3/4"	10551
L	5 1/8" X 1 3/4" Up to 5 3/8" X 1 7/8"	10552



# PRECISION-FIT RECOIL PAD CROSS REFERENCE GUIDE

Find your make and model below to find the corresponding LimbSaver® Recoil Pad product number.

\*Due to manufacturers' stock deviations, LimbSaver Precision-Fit Recoil Pads are not a guaranteed fit.

**Please also use our templates** to ensure proper fit.

\*All Precision-Fit and Grind-to-Fit® pads are designed for flat butt stocks (unless specified)

\*All pads, unless specified, are approximately 1" in thickness.

\*Precision-Fit pads are not intended to be ground.

## SYNTHETIC STOCKS

MAKE	MODEL	STOCK	AIRTECH®	CLASSIC
Benelli	Sport 1	Synthetic	10810	10401
Benelli	Sport II	Synthetic	10810	10401
Benelli	Nova	Synthetic	10810	10401
Benelli	SBE I	Synthetic	10810	10401
Benelli	SBE II	Synthetic	10810	10401
Benelli	Super Sport	Synthetic	10810	10401
Benelli	MII	Synthetic	10810	10401
Benelli	Cordoba 12/20ga	Synthetic	10810	10401
Benelli-Tactical	Pistol Grip Stock SBE MII (12ga) Pop-in pad	Synthetic		10404
Benelli-Tactical	Pistol Grip Stock Nova	Synthetic		10404
Benelli-Tactical	Pistol Grip Stock Super Sport Pop-in pad	Synthetic		10404
Benelli-Tactical	Pistol Grip Stock MII 12ga Pop-in pad	Synthetic		10404
Benelli-Tactical	Pistol Grip Stock Super Sport Bolt-On	Synthetic		10403
Benelli-Tactical	Pistol Grip Stock M1 Bolt-On	Synthetic		10403
Benelli-Tactical	Pistol Grip Stock SBE Bolt-On	Synthetic		10403
Benelli	M2 21VR W/ Comfort-Tech Stock	Synthetic	10810	10401
Benelli	Super Vinci W/ Comfort-Tech Stock	Synthetic	10810	10401
Benelli	M1/M4 with NOVESKE ADAPTER	Synthetic	10807	10111
Beretta	A300 Outlander	Synthetic	10817	10702
Beretta	A400 Extreme	Synthetic	10817	10702
Beretta	Extrema2 with Kick Off stock-12ga- TX4 Storm	Synthetic	10817	10702
Beretta	Sporting/Competition e.g. DT11-692	Synthetic	10811	10701
Blackhawk	SpecOps Gen II	Synthetic	10811	10701
Blackhawk	Axiom Ultra Light	Synthetic	10811	10701
Blackhawk	Axiom Thumb Hole	Synthetic	10811	10701
Blaser	R8 (5/8" thick pad)	Synthetic		10818
Blaser	R93 Professional Camo Bolt on only (5/8" thick pad)	Synthetic		10012
Blaser	R93 Dark Green Bolt on only (5/8" thick pad)	Synthetic		10012
Blaser	R93 Professional Black Bolt on only (5/8" thick pad)	Synthetic		10012
Browning	Gold 12 * 20ga only.	Synthetic		10008
Browning	Silver Hunter 12ga	Synthetic		10008
Browning	Silver 12/20 GA	Synthetic		10008
Browning	A-Bolt Stainless Stalker	Synthetic	10801	10002
Browning	BPS 10ga.	Synthetic		10301
Browning	X-Bolt Rifles	Synthetic	10814	
Browning	AB3 (A-Bolt 3) Rifles	Synthetic	10814	
Choate	ALL stocks that use the mark5 Spacer System	Synthetic	10812	
Christensen Arms	Carbon Summit Rifle	Synthetic	10805	10101
Christensen Arms	Carbon Classic Rifle	Synthetic	10805	10101
Colt	LE6920 Series	Synthetic		10019
Colt	LE6920 Law Enforcement 30+1 223REM/5.56NATO	Synthetic		10019
Colt	LE6940 Series	Synthetic		10019
DPMS	GII AP4	Synthetic		10019
Franchi	Verimax 912 12ga	Synthetic	10810	10401
Harrington/Richards	Handi-Rifle, Adult synthetic - Straight/ Monte Carlo	Synthetic		10018
Knight	50cal. Disc Inline ML	Synthetic	10801	10002
Magpul	ACS Mag 370/371 (5/8" thick pad)	Synthetic		10025
Magpul	CTR Mag 310/311 (5/8" thick pad)	Synthetic		10025
Magpul	ACS-L Mag 378/379 (5/8" thick pad)	Synthetic		10025
Magpul	CTR Mag 310/311 (5/8" thick pad)	Synthetic		10025
Magpul	MOE Mag 400/401 (5/8" thick pad)	Synthetic		10025
Magpul	STR Mag 470/471 (5/8" thick pad)	Synthetic		10025
Magpul	UBR Collapsible Stock Mag 330- Mil-Spec	Synthetic		10025
Magpul	SGA Stocks with the SGA with Adapter	Synthetic	10805	10101
Marlin	Model XS7	Synthetic	10805	10101
Mossberg	500A	Synthetic	10809	10201
Mossberg	535	Synthetic	10809	10201
Mossberg	695	Synthetic	10809	10201
Mossberg	835	Synthetic	10809	10201

# PRECISION-FIT RECOIL PAD CROSS REFERENCE GUIDE

Find your make and model below to find the corresponding LimbSaver® Recoil Pad product number.

\*Due to manufacturers' stock deviations, LimbSaver Precision-Fit Recoil Pads are not a guaranteed fit.

**Please also use our templates** to ensure proper fit.

\*All Precision-Fit and Grind-to-Fit® pads are designed for flat butt stocks (unless specified)

\*All pads, unless specified, are approximately 1" in thickness.

\*Precision-Fit pads are not intended to be ground.

## SYNTHETIC STOCKS

MAKE	MODEL	STOCK	AIRTECH®	CLASSIC
Mossberg	590 A1	Synthetic	10809	10201
Mossberg	590SP 12ga	Synthetic	10809	10201
Mossberg	930 (NON SPX)	Synthetic	10809	10201
Mossberg	935 NON-Pistol Grip	Synthetic	10809	10201
Mossberg	Maverick 88 12ga	Synthetic	10809	10201
Mossberg	Maverick 88 20ga	Synthetic	10807	10111
Mossberg	ATI pistol grip non-tactical	Synthetic	10802	10003
Mossberg	MOE 590A1 with SGA Adapter	Synthetic	10805	10101
Mossberg	International™ 715T™	Synthetic		10019
Mossberg	500 - ATI Tactical	Synthetic		10019
Mossberg	All 4 3/4" buttstocks	Synthetic		10121
Remington	700 SPS	Synthetic	10805	10101
Remington	700 ADL	Synthetic	10805	10101
Remington	700 BDL	Synthetic	10805	10101
Remington	700 LVSF	Synthetic	10816	10601
Remington	700 ML	Synthetic	10805	10101
Remington	710	Synthetic	10805	10101
Remington	770	Synthetic	10805	10101
Remington	870	Synthetic	10805	10101
Remington	870 Express	Synthetic	10805	10101
Remington	870 Express Tactical	Synthetic	10805	10101
Remington	1100 Competition	Synthetic	10805	10101
Remington	1100 Tactical 12/22 OD-Green	Synthetic	10805	10101
Remington	11-87	Synthetic	10805	10101
Remington	7600	Synthetic	10805	10101
Remington	SP-10	Synthetic	10805	10101
Remington	VTR Centerfire	Synthetic	10805	10101
Remington	870 Magnum Special Purpose	Synthetic	10806	10102
Remington	Titanium	Synthetic	10816	10601
Ruger	American	Synthetic	10825	
Ruger	American Magnum	Synthetic	10825	
Ruger	American Predator	Synthetic	10825	
Ruger	American LH	Synthetic	10825	
Ruger	American All Weather	Synthetic	10825	
Ruger	American Crossfire	Synthetic	10825	
Ruger	American Ranch	Synthetic	10825	
Ruger	American Compact	Synthetic	10824	
Ruger	American All Weather Compact	Synthetic	10824	
Ruger	M77	Synthetic	10800	10001
Ruger	Hawkeye	Synthetic	10800	10001
Ruger	77, Mark II, Factory Skeleton Stock-(Request Adapter from us)	Synthetic	10803	10011
Sako	75	Synthetic	10803	10011
Sako	Finnlight	Synthetic	10803	10011
Savage	93 R-AC-TR	Synthetic		10301
Savage	A17	Synthetic	10808	10112
Smith & Wesson	M&P®15T Tactical with M-LOK®	Synthetic		10019
Smith & Wesson	M&P®15 1 in 7" Twist	Synthetic		10019
Smith & Wesson	M&P 15 Sport II 5.56 NATO 16" 30+1	Synthetic		10019
Stag Arms	AR-15 Model 1	Synthetic		10019
Stag Arms	AR-15 Model 1L	Synthetic		10019
Stag Arms	AR-15 Model 2	Synthetic		10019
Stag Arms	AR-15 Model 2L	Synthetic		10019
Stag Arms	AR-15 Model 2T	Synthetic		10019
Stag Arms	AR-15 Model 2TL	Synthetic		10019
Stag Arms	AR-15 Model 3	Synthetic		10019
Stoeger	M3000	Synthetic	10823	
Stoeger	3500	Synthetic	10823	
Stoeger	M2000 (No Pistol Grip)	Synthetic		10008
Stoeger	P-350 Pump	Synthetic		10008



# PRECISION-FIT RECOIL PAD CROSS REFERENCE GUIDE

Find your make and model below to find the corresponding LimbSaver® Recoil Pad product number.

\*Due to manufacturers' stock deviations, LimbSaver Precision-Fit Recoil Pads are not a guaranteed fit.

**Please also use our templates** to ensure proper fit.

\*All Precision-Fit and Grind-to-Fit® pads are designed for flat butt stocks (unless specified)

\*All pads, unless specified, are approximately 1" in thickness.

\*Precision-Fit pads are not intended to be ground.

## SYNTHETIC STOCKS

MAKE	MODEL	STOCK	AIRTECH®	CLASSIC
Tapco	AK T6™ Stock	Synthetic		10019
Tapco	Mil-Spec Profile AR T6™	Synthetic		10019
Tapco	INTRAFUSE T6 AK-47 Collapsible Stock for Stamped Receiver	Synthetic		10019
Thomp Ctr Arms	Triumph	Synthetic	10804	10031
Thomp Ctr Arms	Triumph Bone Collector	Synthetic	10804	10031
Thomp Ctr Arms	Pro Hunter	Synthetic	10804	10031
Thomp Ctr Arms	Pro Hunter Predator	Synthetic	10804	10031
Thomp Ctr Arms	Pro Hunter FX	Synthetic	10804	10031
Thomp Ctr Arms	Pro Hunter Turkey	Synthetic	10804	10031
Thomp Ctr Arms	Pro Hunter Shotgun Slug	Synthetic	10804	10031
Thomp Ctr Arms	Venture	Synthetic	10804	10031
Thomp Ctr Arms	Encore Pro Hunter	Synthetic	10804	10031
Thomp Ctr Arms	Omega ML	Synthetic	10804	10031
Thomp Ctr Arms	Black Diamond	Synthetic	10804	10031
Tikka	T3X	Synthetic	10826	
Tikka	T3 Lite Adjustable	Synthetic	10803	10011
Tikka	T3 Battue Lite Rifle 30.06, 9.3x62	Synthetic	10803	10011
Weatherby	PA-08 12ga	Synthetic	10807	10111
Winchester	Model 1300	Synthetic		10301
Winchester	Model 70 Super Shadow - 4 ¾"	Synthetic	10816	10601

## WOOD STOCKS

MAKE	MODEL	STOCK	AIRTECH®	CLASSIC
Benelli	Super Black Eagle 12ga	Wood	10810	10401
Benelli	20ga Ultralight Satin Walnut with WeatherCoat™	Wood	10810	10401
Beretta	A300 Outlander	Wood	10817	10702
Beretta	A400 Excel	Wood	10817	10702
Beretta	690 Sporting W/ Kick Off	Wood	10817	10702
Beretta	692 Sporting W/ Kick Off	Wood	10817	10702
Beretta	Sporting/Competition e.g. DT11-692	Wood	10811	10701
Browning	BPS Upland 20ga	Wood	10815	10030
Browning	BPS Upland 12ga	Wood	10801	10002
Browning	X-Bolt Rifles	Wood	10814	
Browning	AB3 (A-Bolt 3) Rifles	Wood	10814	
Franchi	Alcoine 12 ga	Wood	10800	10001
Harrington/Richards	SB2-988 Slug Hunter	Wood/Lam	10802	10003
Harrington/Richards	Ultra Slug Hunter (pad screw hole modification)	Wood	10816	10601
Mossberg	Mossberg 500 12ga with Wood Stock (Model: 54264)	Wood	10816	10601
Mossberg	100ATR Rifle White Tail Lightening	Wood	10809	10201
Remington	750	Wood	10806	10102
Remington	870 Wing Master (non-Express)	Wood	10806	10102
Remington	870 Police-12/18/20ga	Wood	10806	10102
Remington	1100 G3	Wood	10806	10102
Remington	Model 1187 SP 1992 yr - 35 Whelen	Wood	10806	10102
Remington	1187 4/7	Wood	10808	10112
Remington	1100 2/5	Wood	10808	10112
Remington	7 CDL	Wood	10808	10112
Remington	673 guide gun	Wood	10808	10112
Remington	700 DM	Wood	10808	10112
Sako	75	Wood	10803	10011
Thomp Ctr Arms	Encore Pro Hunter	Wood	10815	10030
Thomp Ctr Arms	Thunderhawk 50cal	Wood	10806	10102
Thomp Ctr Arms	Omega ML	Wood	10815	10030
Thomp Ctr Arms	Black Diamond	Wood	10815	10030
Tikka	T3X	Wood	10826	
Tikka	T3 Lite - all models except T3 Sporter	Wood	10803	10011
Winchester	Model 12 Heavy Duck 12ga.	Wood	10808	10112